

The working principle of air-displacement pipettes

What are air-displacement pipettes ?

Three things to remember

1. Recommended for aqueous samples and for general laboratory work
2. Always have a cushion of air (dead volume) between the pipette piston and the liquid sample
3. The piston is a permanent part of the pipette

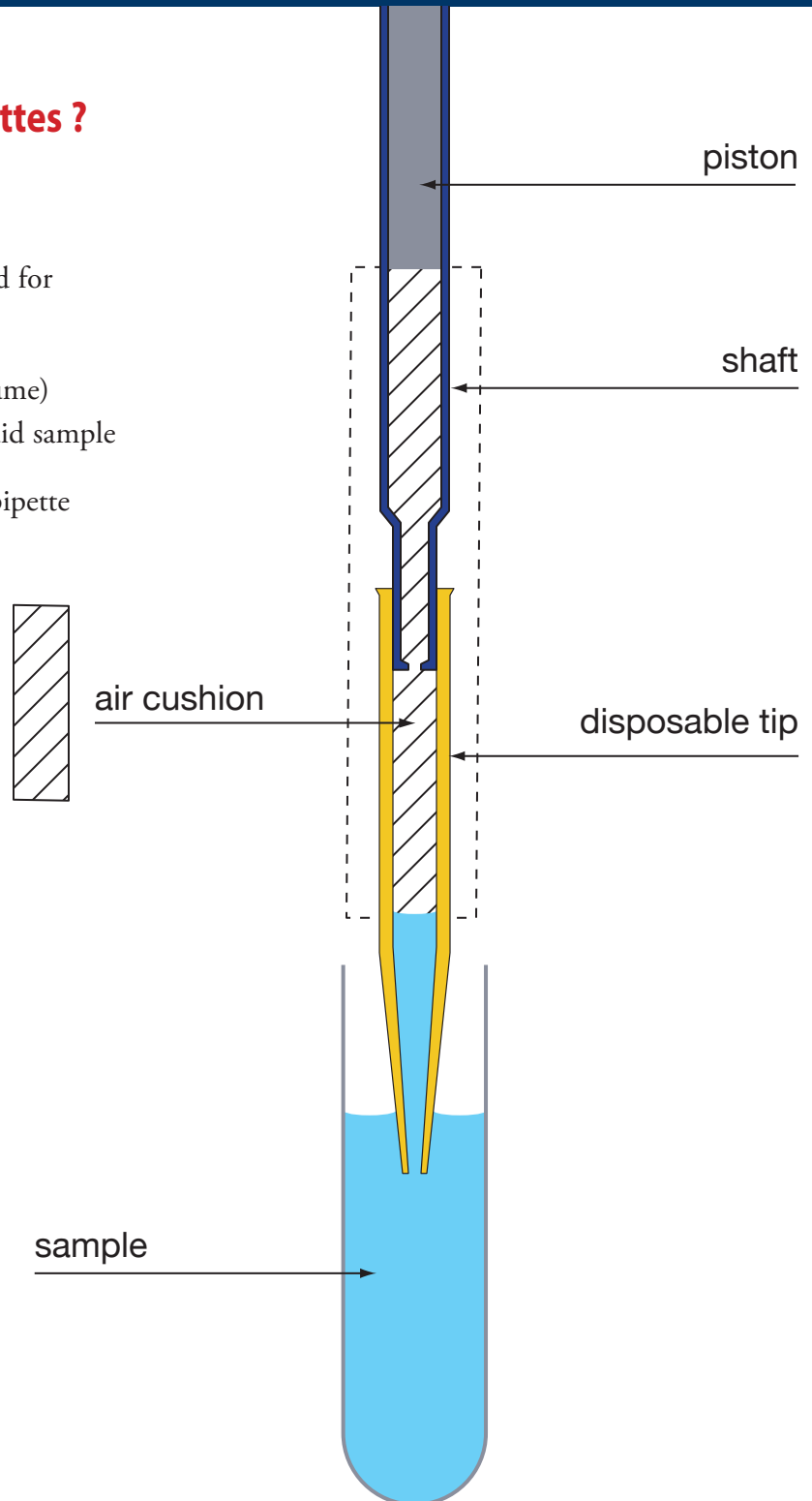

How do air-displacement pipettes work?

When the push-button is pressed on an air-displacement pipette, the piston inside the instrument moves down to let air out. Air is displaced by the piston. The volume of air displaced is equivalent to the volume of liquid aspirated.

The schematic drawings (below) show how the piston determines the volume of air displaced and subsequently the volume of sample aspirated.

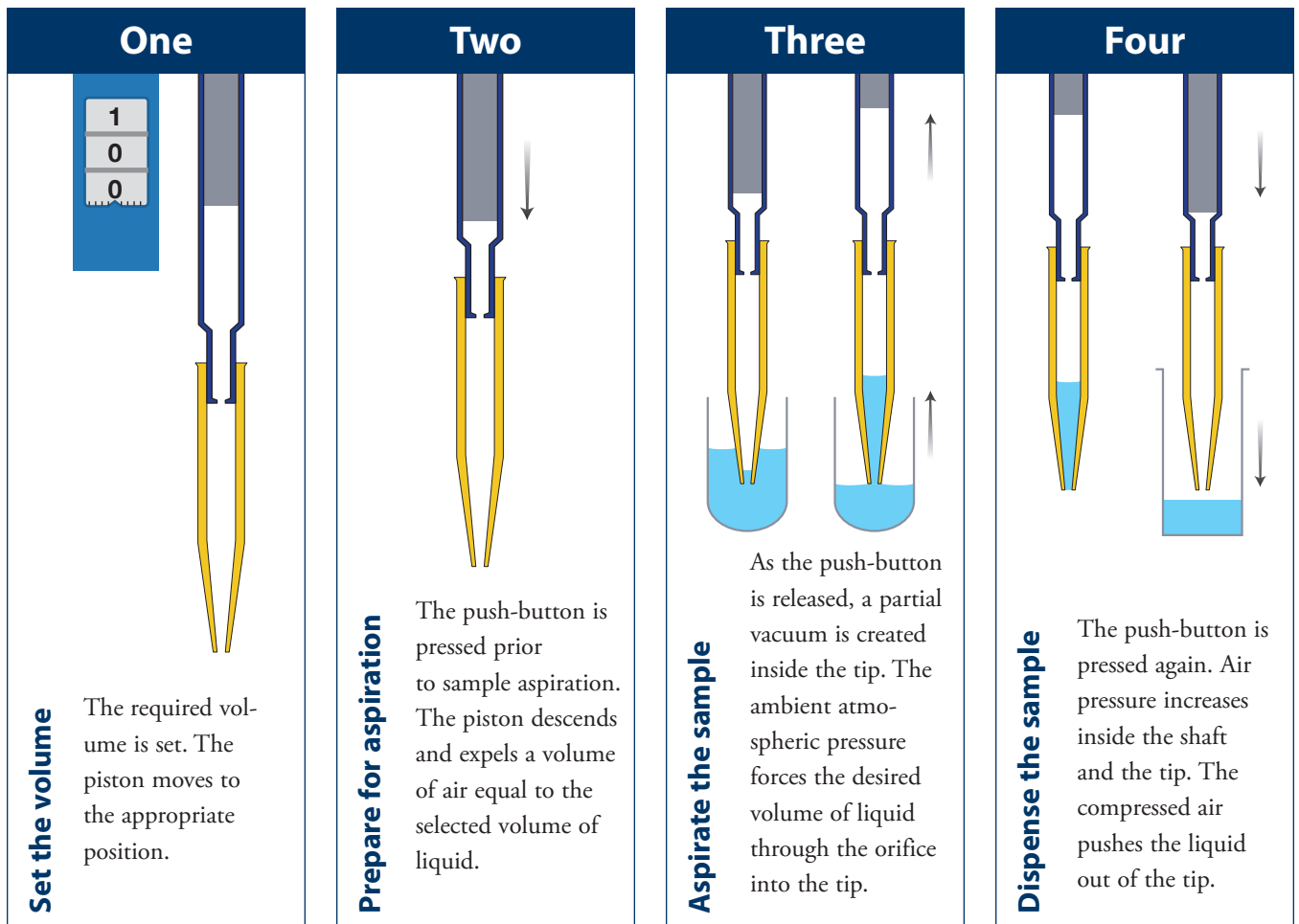

Air-displacement / Forward mode

In general, the precision of the forward mode relies on precise draining by air pressure (air-displacement pipettors) or internal wiping of the pipette barrel (positive-displacement pipettors).

1

Preparation

Hold the instrument in a nearly vertical position. Depress the plunger smoothly to the first stop position.

rest position
first stop
second stop or purge

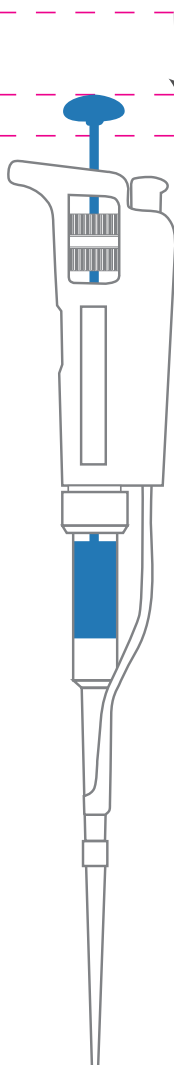

2

Aspiration

Immerse the pipette tip in the liquid*. Allow the plunger to move up smoothly to the rest position. Wait one second so that all the liquid has time to move up into the tip.

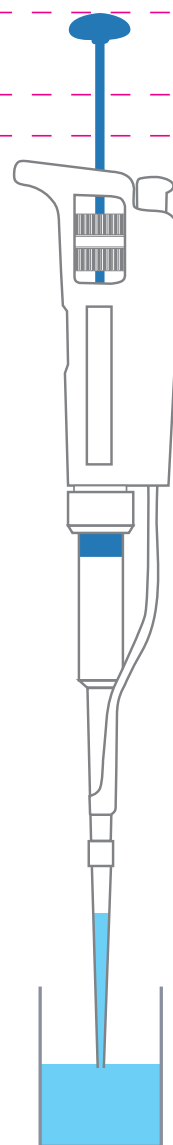

* The immersion depth of your tip can have a significant effect on your results. If the tip is immersed too deeply, droplets will form on the outside of the tip and they will be deposited along with your sample. If the tip is not immersed deeply enough, vortexing will occur and your pipette will not aspirate the selected volume.

volume μl	immersion depth mm
0.1 - 1	1
1 - 100	2-3
101 - 1000	2-4
1001 μl -10 ml	3-6

3**Distribution**

Place the pipette tip at an angle (10 to 45°) against the inside wall of the receiving vessel. Depress the plunger smoothly to the first stop position.

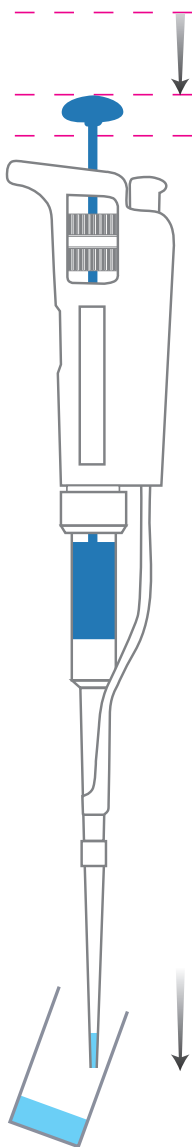
**4****Purge**

Wait one second, then depress the plunger to the second stop position. This “blow-out” stroke removes any remaining sample from the tip. Remove pipette tip end from sidewall by sliding it up the wall.

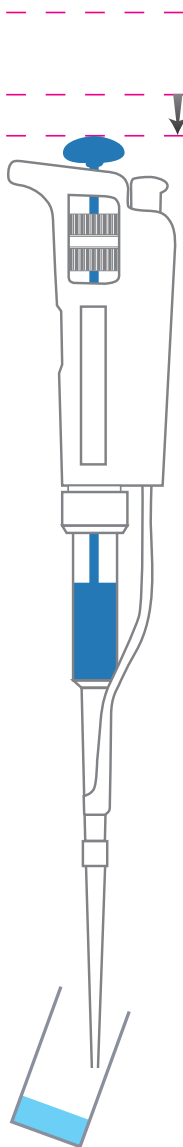
**5****Home**

Allow the plunger to move up to the rest position.

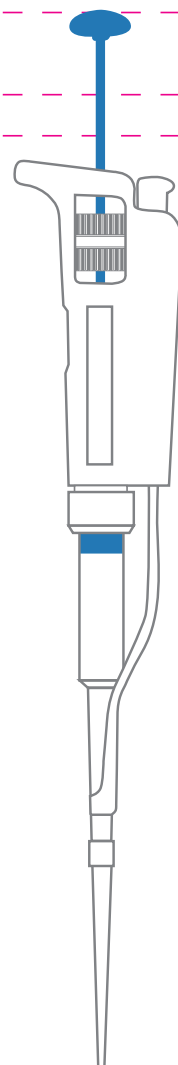

Air-displacement / Reverse mode

In reverse mode pipetting, the purge stroke is used during preparation. During aspiration, an amount of liquid equal to the amount of purged air is added. This amount compensates for the liquid that remains as film inside the tip during dispensing.

1

Preparation

Hold the instrument in a nearly vertical position. Depress the plunger smoothly to the second stop position.

rest position
first stop
second stop or purge

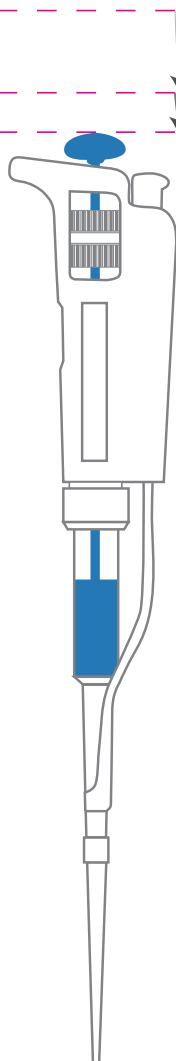

2

Aspiration

Immerse the pipette tip in the liquid*. Allow the plunger to move up smoothly to the rest position. Wait one second so that all the liquid has time to move up into the tip.

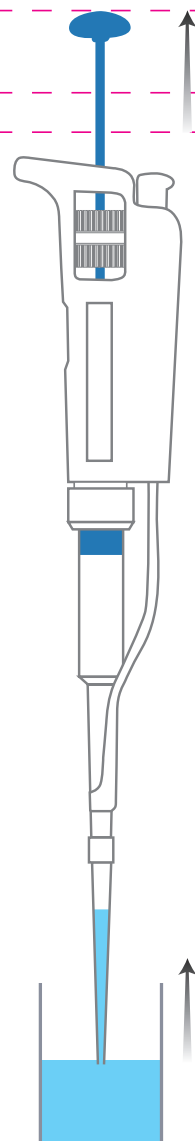

3

Distribution

Place the pipette tip at an angle (10 to 45°) against the inside wall of the receiving vessel. Depress the plunger smoothly to the first stop position. Wait one second.

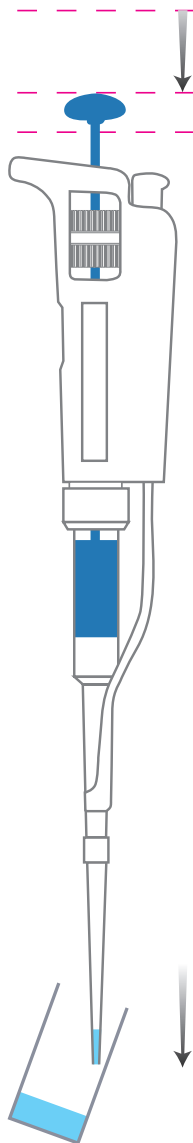
**4**

Re-aspiration

If the pipette tip is to be reused for the same sample, maintain the plunger in the intermediate position for subsequent immersion for the next pipetting cycle and restart operation 2.

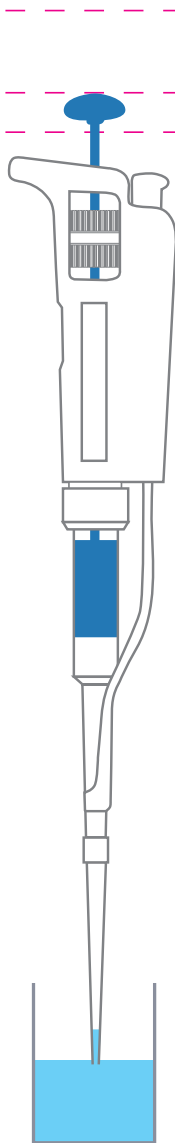
**5**

Complete purge

Wait one second and purge. If the pipette tip is not to be re-used, depress the plunger to the purge position over an appropriate waste container and then eject the tip.

